

chrozen ASTM D5580 Player

 **YOUNG IN**
Chromass 

Алматы (7273)495-231
Ангарск (3955)60-70-56
Архангельск (8182)63-90-72
Астрахань (8512)99-46-04
Барнаул (3852)73-04-60
Белгород (4722)40-23-64
Благовещенск (4162)22-76-07
Брянск (4832)59-03-52
Владивосток (423)249-28-31
Владикавказ (8672)28-90-48
Владимир (4922)49-43-18
Волгоград (844)278-03-48
Вологда (8172)26-41-59
Воронеж (473)204-51-73
Екатеринбург (343)384-55-89

Иваново (4932)77-34-06
Ижевск (3412)26-03-58
Иркутск (395)279-98-46
Казань (843)206-01-48
Калининград (4012)72-03-81
Калуга (4842)92-23-67
Кемерово (3842)65-04-62
Киров (8332)68-02-04
Коломна (4966)23-41-49
Кострома (4942)77-07-48
Краснодар (861)203-40-90
Красноярск (391)204-63-61
Курск (4712)77-13-04
Курган (3522)50-90-47
Липецк (4742)52-20-81

Магнитогорск (3519)55-03-13
Москва (495)268-04-70
Мурманск (8152)59-64-93
Набережные Челны (8552)20-53-41
Нижний Новгород (831)429-08-12
Новокузнецк (3843)20-46-81
Ноябрьск (3496)41-32-12
Новосибирск (383)227-86-73
Омск (3812)21-46-40
Орел (4862)44-53-42
Оренбург (3532)37-68-04
Пенза (8412)22-31-16
Петрозаводск (8142)55-98-37
Псков (8112)59-10-37
Пермь (342)205-81-47

Ростов-на-Дону (863)308-18-15
Рязань (4912)46-61-64
Самара (846)206-03-16
Санкт-Петербург (812)309-46-40
Саратов (845)249-38-78
Севастополь (8692)22-31-93
Саранск (8342)22-96-24
Симферополь (3652)67-13-56
Смоленск (4812)29-41-54
Сочи (862)225-72-31
Ставрополь (8652)20-65-13
Сургут (3462)77-98-35
Сыктывкар (8212)25-95-17
Тамбов (4752)50-40-97
Тверь (4822)63-31-35

Тольятти (8482)63-91-07
Томск (3822)98-41-53
Тула (4872)33-79-87
Тюмень (3452)66-21-18
Ульяновск (8422)24-23-59
Улан-Удэ (3012)59-97-51
Уфа (347)229-48-12
Хабаровск (4212)92-98-04
Чебоксары (8352)28-53-07
Челябинск (351)202-03-61
Череповец (8202)49-02-64
Чита (3022)38-34-83
Якутск (4112)23-90-97
Ярославль (4852)69-52-93

Россия +7(495)268-04-70

Казахстан +7(7172)727-132

Киргизия +996(312)96-26-47

<https://youngin.nt-rt.ru/> || y nb@nt-rt.ru

Aromatic compounds including BTEX (benzene, toluene, ethylbenzene and xylene) are used for gasoline to increase its octane rating. Because they trigger to form the ozone and can cause toxicity to human, these pollutants are to be regulated by measuring the % content of benzene and total aromatic compounds in gasoline through several fuel regulations.

ASTM D5580 is the mainly used method for determination of benzene, toluene, ethylbenzene, p/m-xylene, o-xylene, C9 and heavier aromatics in finished gasoline and the accurate backflush time control is required to have the all compounds completely separated in the analysis.

ChroZen ASTM D5580 Player is the optimized system to determine the % concentration of these compounds by complying with ASTM D5580 and verifies the validity of analysis results for each analysis method.



Summary of Test Method

Aromatic compounds in gasoline were analyzed by ChroZen ASTM D5580 Player and two columns were used; micro-packed TCEP as pre-column and PDMS (Dimethylpolysiloxance) non-polar column. There are 2 methods (Methods A and Methods B) described in ASTM D5580 and it is required to choose one of them depending on what to identify.

< Method A >

: Determination of benzene, toluene and 2-hexonone (ISTD)

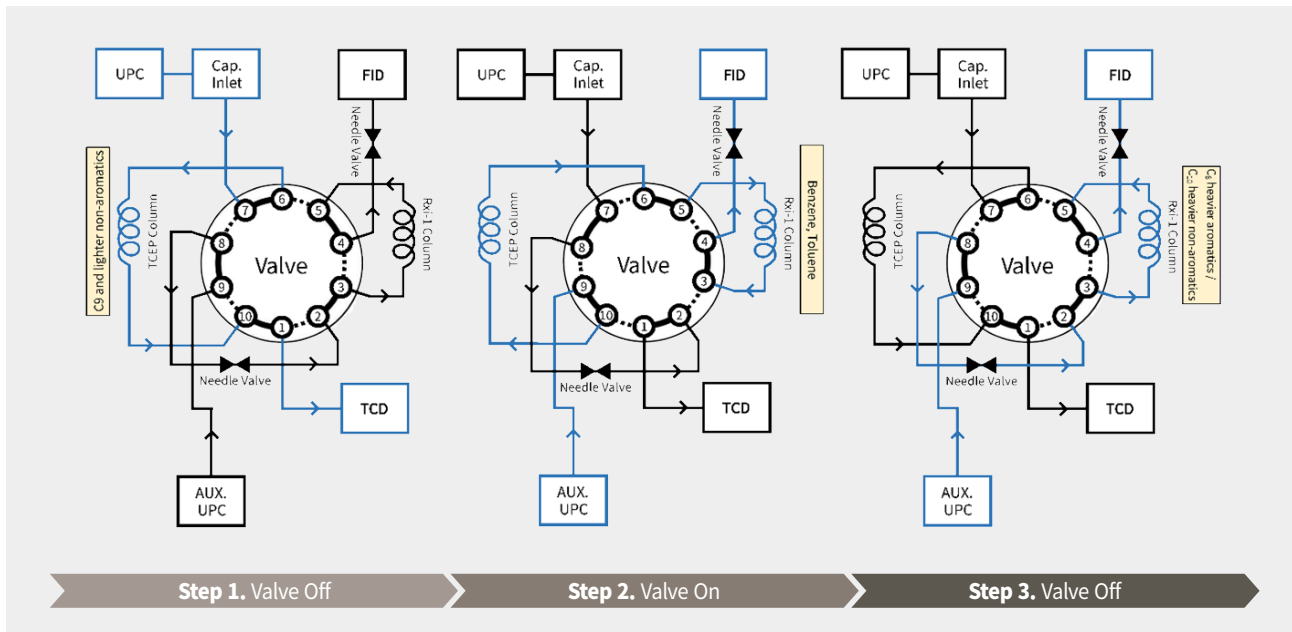

Switching position of 10-port valve for method A

< Method B >

: Determination of ethylbenzene, 2-hexanone (ISTD), o-xylene, C9 and heavier aromatic composite

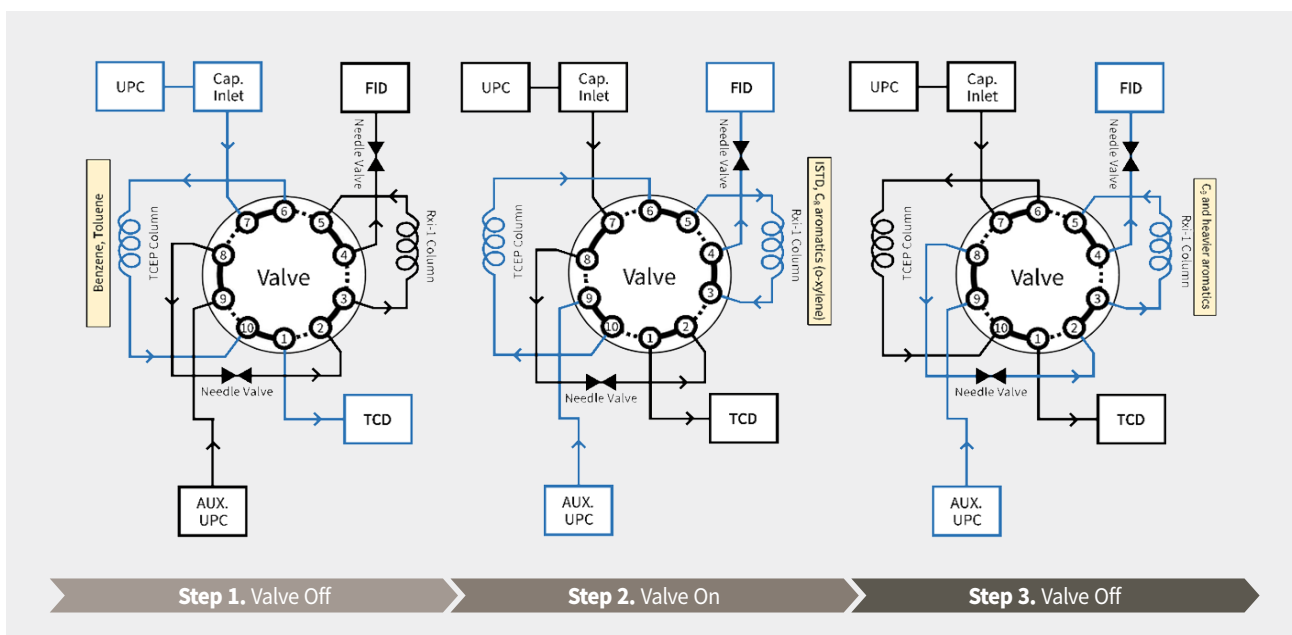

Switching position of 10-port valve for method B

The calibration mixtures of benzene (0.1, 0.5, 1.0, 2.0, 5.0%), toluene (1.0, 2.5, 5.0, 10.0, 15.0%), ethylbenzene, o-xylene and 1,2,4-trimethylbenzene (0.5, 1.0, 2.5, 5.0, 10.0%) were used for calibration curve and the correlation coefficients of all mixture are greater than 0.990 which satisfies ASTM specifications good enough. The calibration curve of benzene is shown as an example.

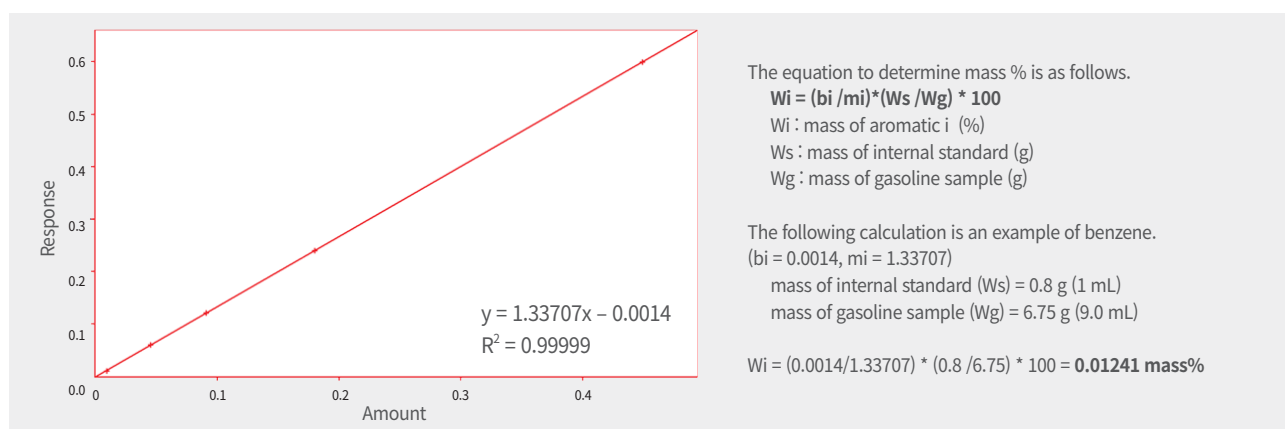

Calibration curve of benzene

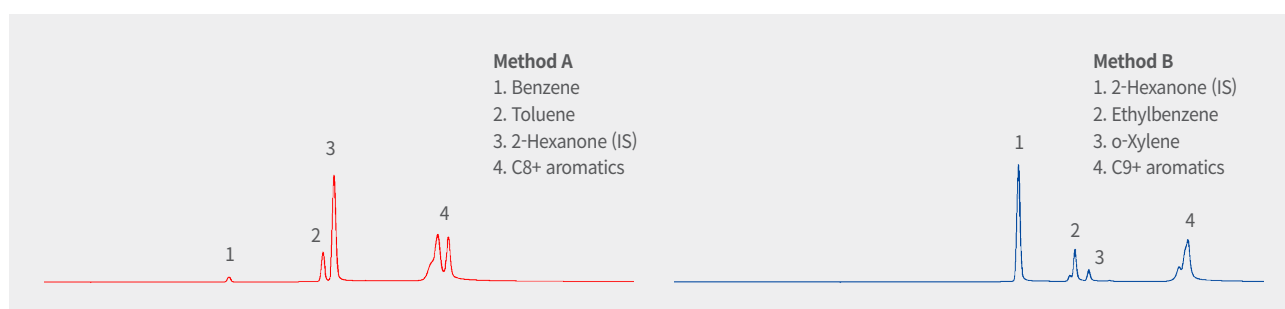

Chromatogram of gasoline sample

The repeatability in 5 sequences is about 0.37-0.85 %RSD, shown on the Table 1. Also, the mass % of all aromatics in gasoline sample is within the limit of ASTM D5580 which is represented on the Table 2.

Table 1. Peak area % RSD of gasoline sample (n=5)

No.	Peak area (pA.s)			
	Benzene	Toluene	Ethyl benzene	o-Xylene
1	806.68	4848.37	1914.20	1695.22
2	803.33	4781.04	1905.90	1703.77
3	803.25	4858.51	1915.35	1703.71
4	800.76	4895.71	1888.73	1698.44
5	808.10	4849.61	1911.55	1722.75
% RSD	0.37	0.85	0.85	0.63

Table 2. Repeatability of gasoline sample

Compound	ASTM D5580 Specification		Analysis Results	
	Range (Mass %)	Repeatability	Mass%	*Repeatability
Benzene	0.14-1.79	0.0265($X^{0.65}$)	0.519	0.008
Toluene	2.11-10.08	0.0301($X^{0.5}$)	2.212	0.051
Ethylbenzene	0.57-2.65	0.029	1.109	0.076
o-Xylene	0.77-3.92	0.0296($X^{0.5}$)	0.809	0.003

X = mass %

* Difference between maximum and minimum mass %

As the result, mass % of aromatics are resulted 0.012 mass % for benzene, 0.131 mass % for toluene, 0.040 mass % for ethylbenzene, 0.033 mass % for o-xylene, 0.077 mass % for 1,2,4-trimethylbenzene each. It is satisfied with the acceptance criteria of ASTM D5580 as < 0.02 mass % for benzene, < 0.2 mass % for other aromatic compounds.

ChroZen ASTM D5580 player fully satisfies all the requirements indicated in ASTM D5580 with the ways in hardware and solutions by showing the great repeatability and linearity for analysis of aromatic compounds in gasoline. The qualified control report with the satisfied results for ASTM D5580 will be supplied along with the system.

ChroZen ASTM D5580 Player

Total Dream Solution includes:

1. Smart Hardware Platform (Based on ChroZen GC)
2. Smart Software Control (Chromatography Data System)
3. All Related Consumables and Accessories
4. Columns
 - Column 1 : 20% TCEP Micro-Packed Column on 80/100 Chromosorb P (0.56 m, 750 mm, 1/16")
 - Column 2 : 100 % Dimethylpolysiloxane Non-Polar Column (30 m, 0.53 mm, 5 µm)

Target Compounds Coverage	Benzene
	Toluene
	Ethylbenzene
	p/m-Xylene
	o-Xylene
	1,2,4-Trimethylbenzene
	C9 plus aromatics
	2-hexanone

** ASTM D5580 regulates the % content of each compounds as bellows;
0.1 ~ 5 % for benzene, 1 ~ 15 % for toluene, 0.5 ~ 10 % for C8 aromatics (ethylbenzene, xylenes), 5 ~ 30 % for C9 and heavier aromatics, 10 ~ 80 liquid volume % for total aromatics.*



Алматы (7273)495-231
Ангарск (3955)60-70-56
Архангельск (8182)63-90-72
Астрахань (8512)99-46-04
Барнаул (3852)73-04-60
Белгород (4722)40-23-64
Благовещенск (4162)22-76-07
Брянск (4832)59-03-52
Владивосток (423)249-28-31
Владикавказ (8672)28-90-48
Владимир (4922)49-43-18
Волгоград (844)278-03-48
Вологда (8172)26-41-59
Воронеж (473)204-51-73
Екатеринбург (343)384-55-89

Иваново (4932)77-34-06
Ижевск (3412)26-03-58
Иркутск (395)279-98-46
Казань (843)206-01-48
Калининград (4012)72-03-81
Калуга (4842)92-23-67
Кемерово (3842)65-04-62
Киров (8332)68-02-04
Коломна (4966)23-41-49
Кострома (4942)77-07-48
Краснодар (861)203-40-90
Красноярск (391)204-63-61
Курск (4712)77-13-04
Курган (3522)50-90-47
Липецк (4742)52-20-81

Магнитогорск (3519)55-03-13
Москва (495)268-04-70
Мурманск (8152)59-64-93
Набережные Челны (8552)20-53-41
Нижегород (831)429-08-12
Новокузнецк (3843)20-46-81
Ноябрьск (3496)41-32-12
Новосибирск (383)227-86-73
Омск (3812)21-46-40
Орел (4862)44-53-42
Оренбург (3532)37-68-04
Пенза (8412)22-31-16
Петрозаводск (8142)55-98-37
Псков (8112)59-10-37
Пермь (342)205-81-47

Ростов-на-Дону (863)308-18-15
Рязань (4912)46-61-64
Самара (846)206-03-16
Санкт-Петербург (812)309-46-40
Саратов (845)249-38-78
Севастополь (8692)22-31-93
Саранск (8342)22-96-24
Симферополь (3652)67-13-56
Смоленск (4812)29-41-54
Сочи (862)225-72-31
Ставрополь (8652)20-65-13
Сургут (3462)77-98-35
Сыктывкар (8212)25-95-17
Тамбов (4752)50-40-97
Тверь (4822)63-31-35

Тольятти (8482)63-91-07
Томск (3822)98-41-53
Тула (4872)33-79-87
Тюмень (3452)66-21-18
Ульяновск (8422)24-23-59
Улан-Удэ (3012)59-97-51
Уфа (347)229-48-12
Хабаровск (4212)92-98-04
Чебоксары (8352)28-53-07
Челябинск (351)202-03-61
Череповец (8202)49-02-64
Чита (3022)38-34-83
Якутск (4112)23-90-97
Ярославль (4852)69-52-93

Россия +7(495)268-04-70

Казахстан +7(7172)727-132

Киргизия +996(312)96-26-47

<https://youngin.nt-rt.ru/> || ybn@nt-rt.ru